

# Digital Arts and Humanities Workshop Series – Spring 2018

Fridays @ noon -- Scholars Commons IQ-Wall

Date	Topic	Presenter
Jan. 12	Intro to Digital Humanities	Tassie Gniady
Jan. 19	Intro to Visualization	Michael Boyles
Jan. 26	Intro to R	Tassie Gniady
Feb. 2	Augmented Reality	Chauncey Frend
Feb. 9	Text Analysis of Kurt Vonnegut w/ the HathiTrust & Voyant	Tassie Gniady & Robert McDonald
Feb. 16	Virtual Reality	Bill Sherman
Feb. 23	R for Twitter	Tassie Gniady
Mar. 2	Advanced Media	Chris Eller
Mar. 23	3D Object Acquisition & Printing	Jeff Rogers
Mar. 30	Network Graphs	David Kloster
Apr. 6	3D Photogrammetry	Tassie Gniady
Apr. 13	IQ-Table & Touch-Enabled Software Workflows	David Reagan
Apr. 20	Omeka S and 3D Collections	Tassie Gniady & Will Cowan



# 3D Scanning

## within the UITS Advanced Visualization Lab

*(for the digital arts & humanities at Indiana University)*

Jeff Rogers and Tyler Jackson  
Principal Project Analyst, Advanced Visualization Lab  
Indiana University

March 23, 2018



**RESEARCH  
TECHNOLOGIES**

INDIANA UNIVERSITY  
University Information Technology Services



**PERVASIVE TECHNOLOGY  
INSTITUTE**

INDIANA UNIVERSITY



# Goals for Today

## Goals

- Example projects
- Why digitize?
- 3D digitization technologies available @ IU
  - 3D Software modeling
  - Software-based photogrammetry (04-06-2018)
  - Hardware-based volumetric
  - Hardware-based 3D surface scanning (Today's tech focus)
- Hardware-based 3D surface scanning
- Post-processing workflows for all digitization technologies
- Recommended scanning and printing resources



**RESEARCH  
TECHNOLOGIES**

INDIANA UNIVERSITY  
University Information Technology Services



**PERVASIVE TECHNOLOGY  
INSTITUTE**

INDIANA UNIVERSITY



# 3D Digitization Example Projects

- Medical Related
  - CIFASD Imaging with Tatiana Foroud, Ph.D.
  - Travis Bellicchi Prosthodontics Fabrication

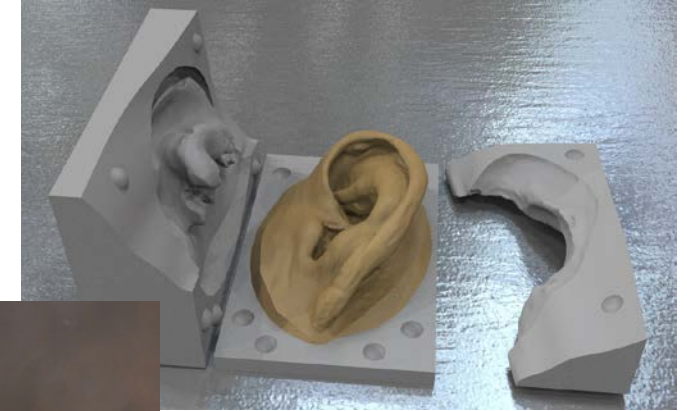
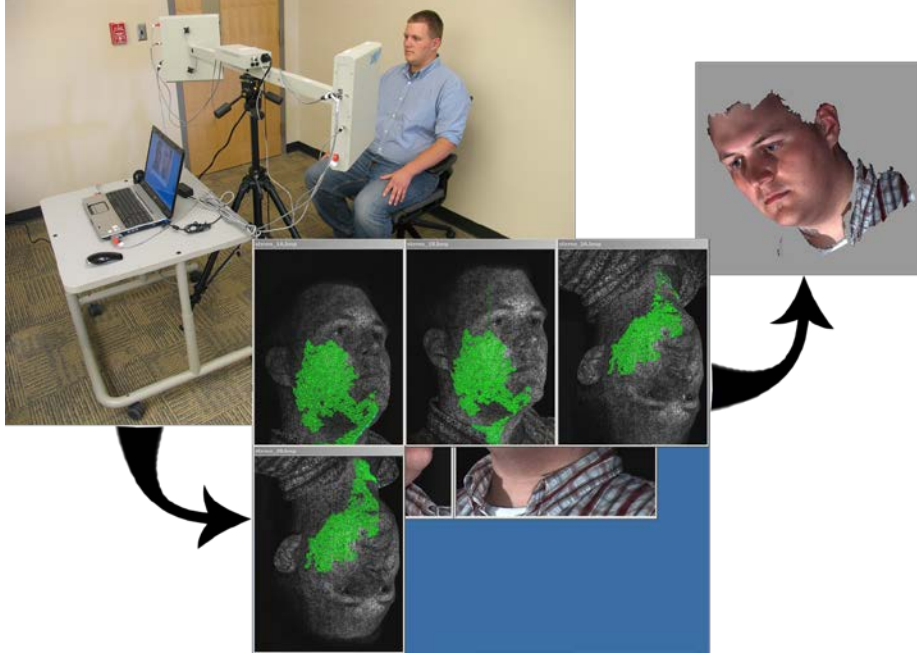

**RESEARCH  
TECHNOLOGIES**

INDIANA UNIVERSITY  
University Information Technology Services



**PERVASIVE TECHNOLOGY  
INSTITUTE**

INDIANA UNIVERSITY



# 3D Digitization Example Projects

- Cultural Heritage
  - Benjamin Harrison Presidential Site
  - Ruth Lilly Medical Libraries
  - Dr. Leo J McCarthy Collection
  - Old Oaken Bucket



**RESEARCH  
TECHNOLOGIES**

INDIANA UNIVERSITY  
University Information Technology Services



**PERVASIVE TECHNOLOGY  
INSTITUTE**

INDIANA UNIVERSITY

# Why Digitize?

- Digital preservation
- Artifact/Part analysis
- Metrology for reverse engineering, part inspection, redesign, and manufacture
- Reproduction through 3D printing



**RESEARCH  
TECHNOLOGIES**

INDIANA UNIVERSITY  
University Information Technology Services



**PERVASIVE TECHNOLOGY  
INSTITUTE**

INDIANA UNIVERSITY



# 3D Digitization vs. 3D Modeling

3D Digitization	3D Modeling
<b>Pros</b> <ul style="list-style-type: none"><li>• Faster for complex or organic shapes</li><li>• Captures materials</li></ul>	<b>Pros</b> <ul style="list-style-type: none"><li>• Faster for simple shapes</li><li>• Parameterization inherent to modeling</li></ul>
<b>Cons</b> <ul style="list-style-type: none"><li>• Some materials don't digitize well</li><li>• Parameterization can be cumbersome</li></ul>	<b>Cons</b> <ul style="list-style-type: none"><li>• Time consuming modeling on complex shapes</li><li>• Manual material creation</li></ul>



**RESEARCH  
TECHNOLOGIES**

INDIANA UNIVERSITY  
University Information Technology Services



**PERVASIVE TECHNOLOGY  
INSTITUTE**

INDIANA UNIVERSITY



# 3D Modeling Options

## Measure and Model with Software Tools

- Lots of Software options
  - Polygonal Modeling: Maya, Max, Zbrush, Blender, ...
  - Parametric Modeling: Inventor, Solidworks, Rhino3D, ...
- Requires skills with select modeling packages
- Example Project: Scope Lens Extension



Measure

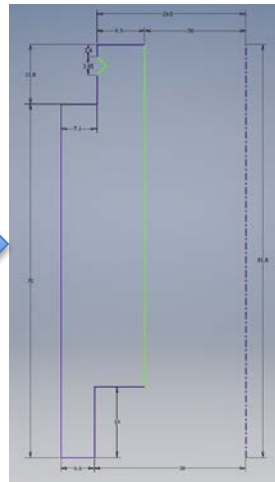

Profile Sketch

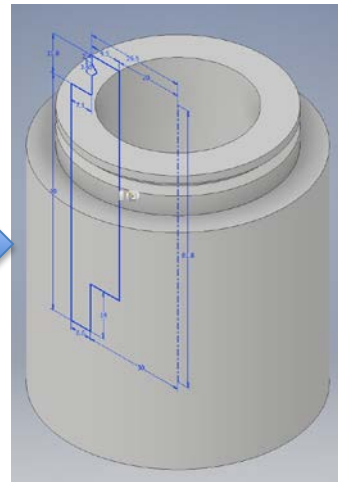

Revolve

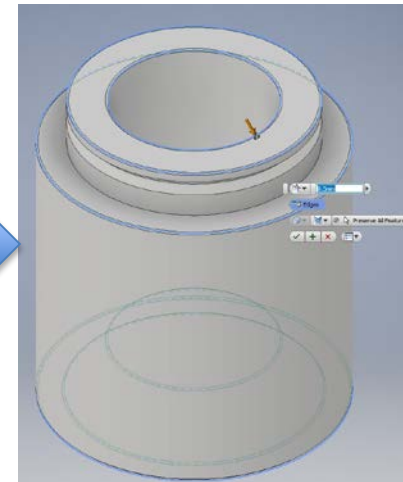

Chamfer

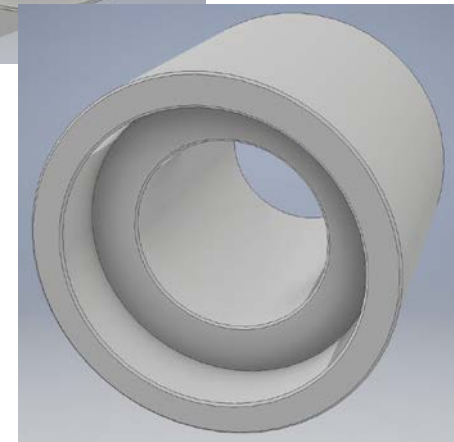
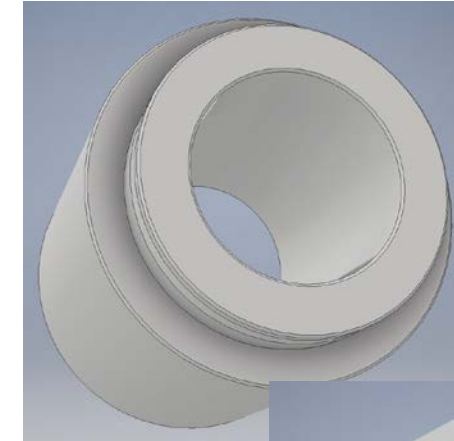

**RESEARCH  
TECHNOLOGIES**

INDIANA UNIVERSITY  
University Information Technology Services



**PERVASIVE TECHNOLOGY  
INSTITUTE**

INDIANA UNIVERSITY





# 3D Digitization Options

## Hardware-Based Surface Scanning

- Structured light scanners
- Laser time-of-flight scanners
- LIDAR systems



Leica LIDAR (> \$50K)



Matterport (\$4K)



NextEngine (\$3K)



Minolta (\$30K - Retired)



GoScan (\$25K)



3DMD (\$45K)



RESEARCH  
TECHNOLOGIES

INDIANA UNIVERSITY  
University Information Technology Services



PERVASIVE TECHNOLOGY  
INSTITUTE

INDIANA UNIVERSITY





# 3D Digitization Options

## Photogrammetry Surface (Friday, Apr 6<sup>th</sup>, 2018)

- Capture 2D Images
- Structure from motion technique

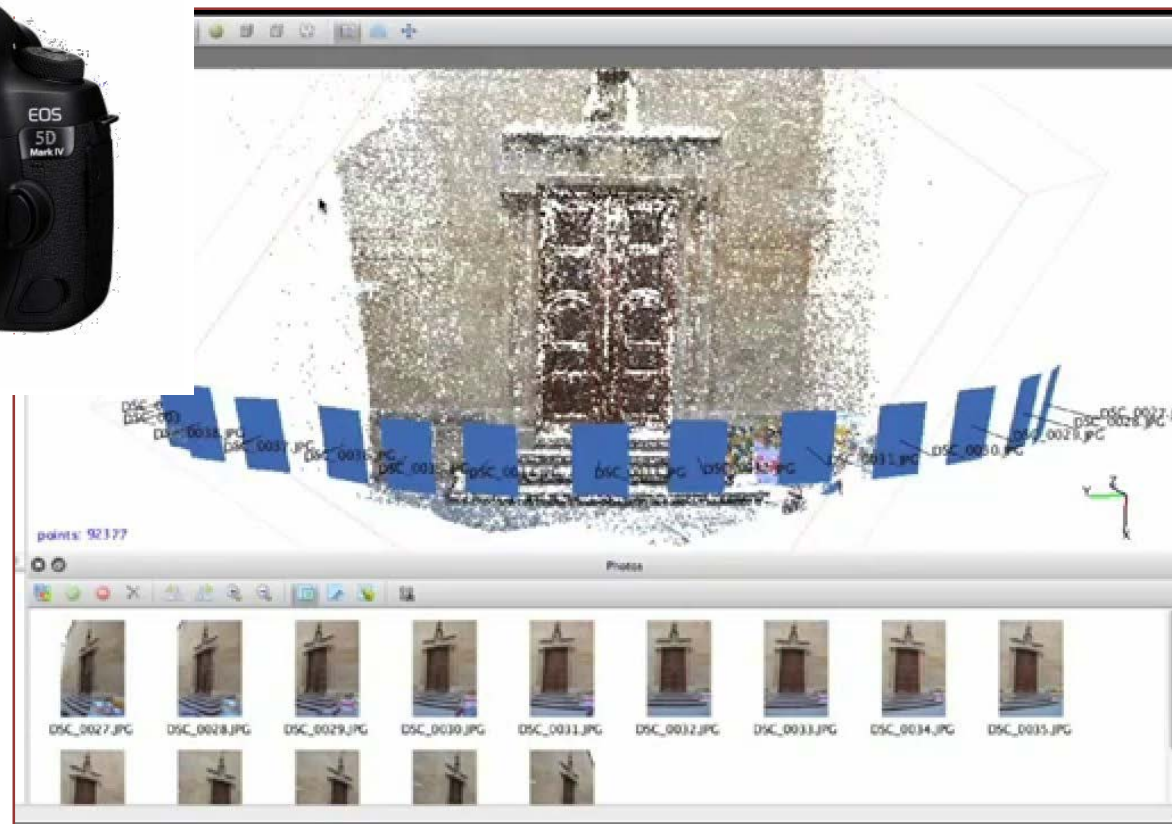

**RESEARCH  
TECHNOLOGIES**

INDIANA UNIVERSITY  
University Information Technology Services



**PERVASIVE TECHNOLOGY  
INSTITUTE**

INDIANA UNIVERSITY



# 3D Digitization Options

## Hardware-Based Volumetric

- CT/ MicroCT/CBCT
- MRI

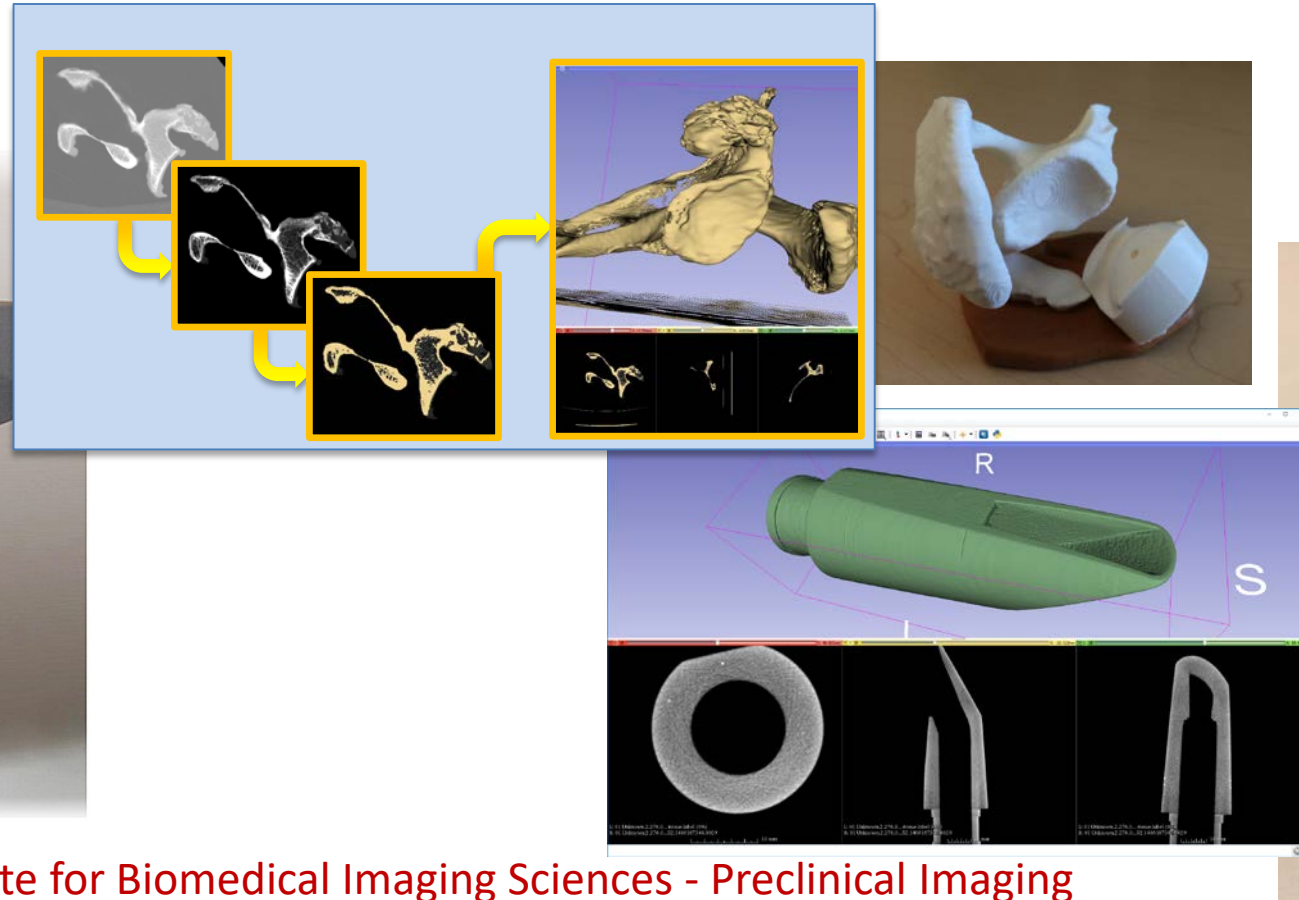

Data Capture: Indiana Institute for Biomedical Imaging Sciences - Preclinical Imaging  
Post Processing Workflows: Tested AVL Workflows in Place



**RESEARCH  
TECHNOLOGIES**

INDIANA UNIVERSITY  
University Information Technology Services



**PERVASIVE TECHNOLOGY  
INSTITUTE**

INDIANA UNIVERSITY



# 3D Digitization Options

Surface Scanning	Photogrammetry	Volumetric Scanning
<p>Pros</p> <ul style="list-style-type: none"><li>• Greater spatial accuracy (&lt;1mm)</li><li>• Less time on site</li><li>• Real-time feedback on quality</li><li>• Less post-processing time</li><li>• Less chance of user error/failed scan</li></ul>	<p>Pros</p> <ul style="list-style-type: none"><li>• Affordable equipment</li><li>• Highly portable</li><li>• Underwater and aerial (drone) compatible</li><li>• Potential to reprocess for greater accuracy</li><li>• Potential for better color capture</li><li>• Potential for more detail capture</li></ul>	<p>Pros</p> <ul style="list-style-type: none"><li>• Captures internal structures</li><li>• Very high resolution (~9um)</li></ul>
<p>Cons</p> <ul style="list-style-type: none"><li>• Expensive equipment</li><li>• Must upgrade equipment to achieve future gains</li></ul>	<p>Cons</p> <ul style="list-style-type: none"><li>• Lower spatial accuracy</li><li>• Lengthy, computationally expensive post-processing (<b>getting faster</b>)</li><li>• Challenges of processing in the field (laptop)</li><li>• Potential inadequacy/failure of photo set</li><li>• More time on site</li></ul>	<p>Cons</p> <ul style="list-style-type: none"><li>• Costly scan</li><li>• Cumbersome Isosurfacing</li><li>• Some materials cause noise</li><li>• Size limitations</li><li>• Object must be brought to scanner</li></ul>

# 3D Digitization Options

## The Decisions

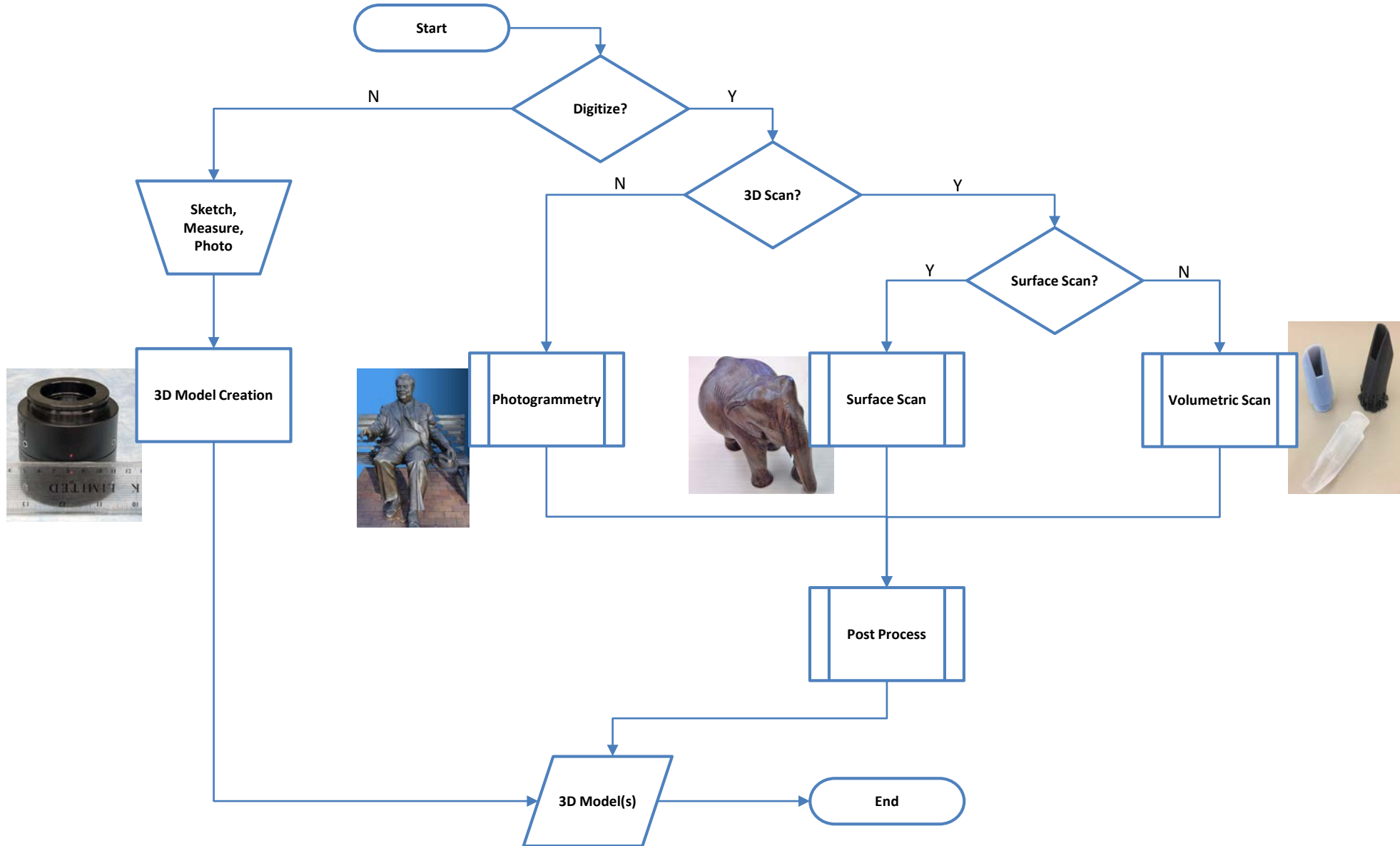

# 3D Digitization Options

## The Decisions

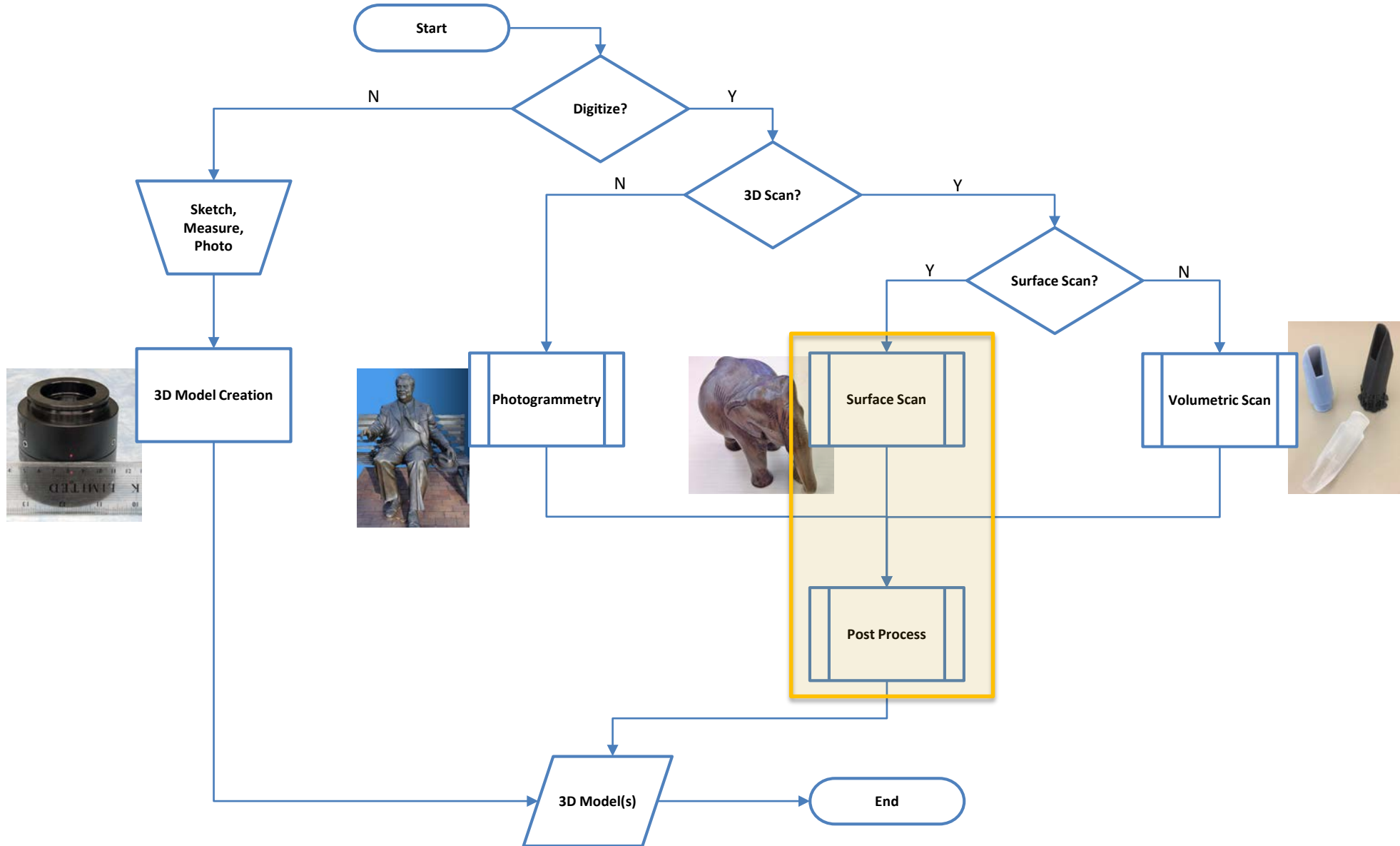

# Hardware-Based 3D Scanning Setup

- Scanner Preparation
  - Calibration
    - Color
    - Resolution
    - 3D mesh options
  - Options
    - Color
    - Resolution
    - 3D mesh options
- Object Preparation
  - Surface preparation
    - Markers when needed
    - Dusting when needed
  - Foresee scan angles

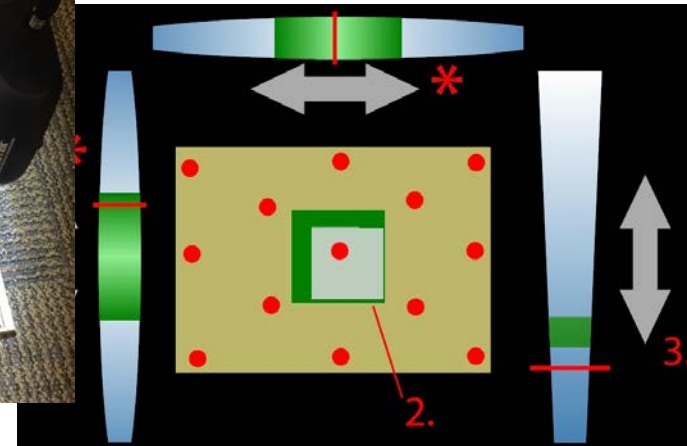

RESEARCH  
TECHNOLOGIES

INDIANA UNIVERSITY  
University Information Technology Services



PERVASIVE TECHNOLOGY  
INSTITUTE

INDIANA UNIVERSITY



# Hardware-Based 3D Scanning

## Scanning

- Scan
- Merge
- (Live Demo)

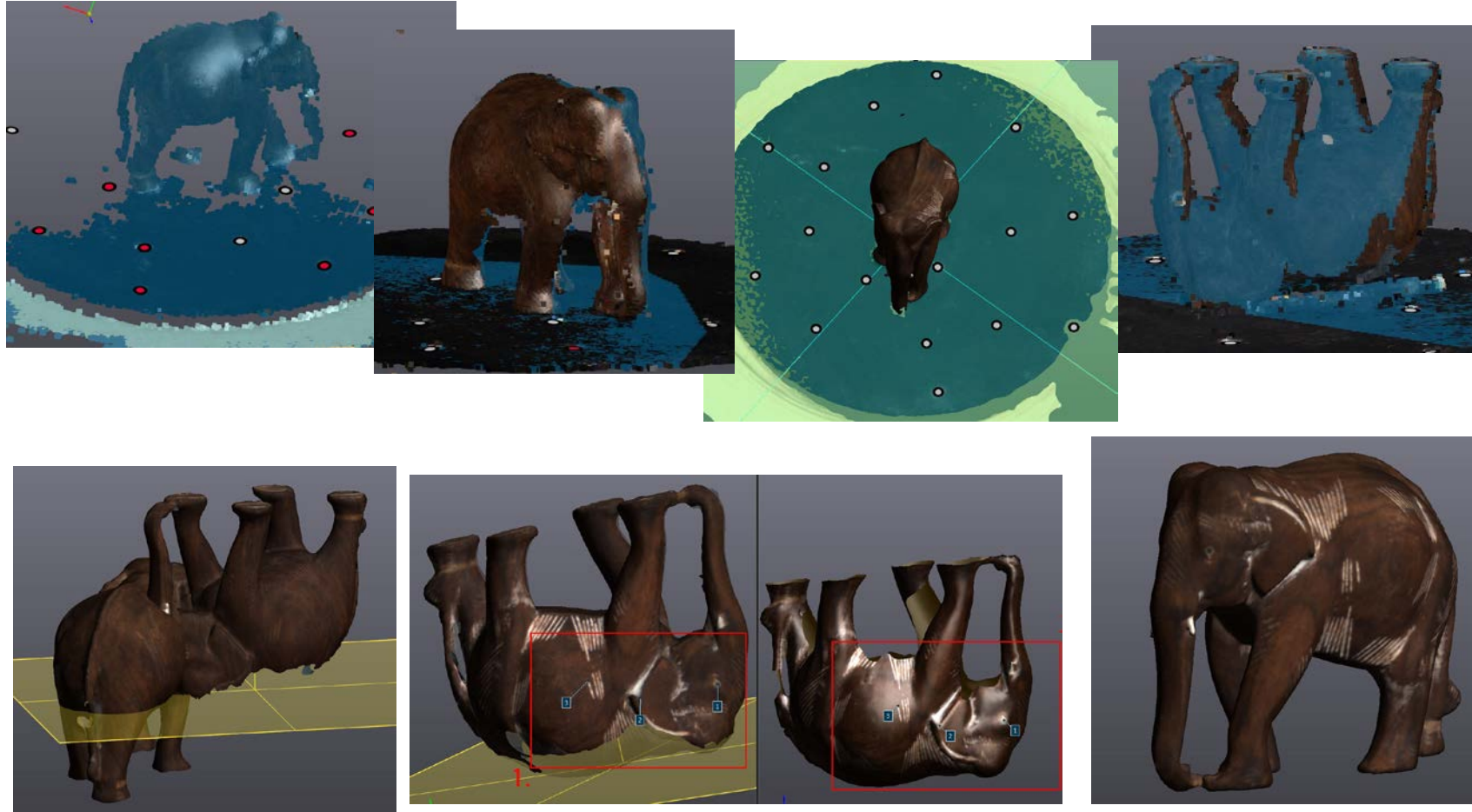

**RESEARCH  
TECHNOLOGIES**

INDIANA UNIVERSITY  
University Information Technology Services



**PERVASIVE TECHNOLOGY  
INSTITUTE**

INDIANA UNIVERSITY





# Hardware-Based 3D Scanning

## Understanding the Limitations

- Accuracy: Certainty at the point of measurement
- Resolution: Distance between points of measurement
- Volumetric Accuracy: Certainty of point within unit of volume
- Example:
  - Creaform GoScan 50
  - Accuracy: 0.1 mm
  - Resolution: 0.5 mm maximum
  - Volumetric accuracy: 0.3mm/m

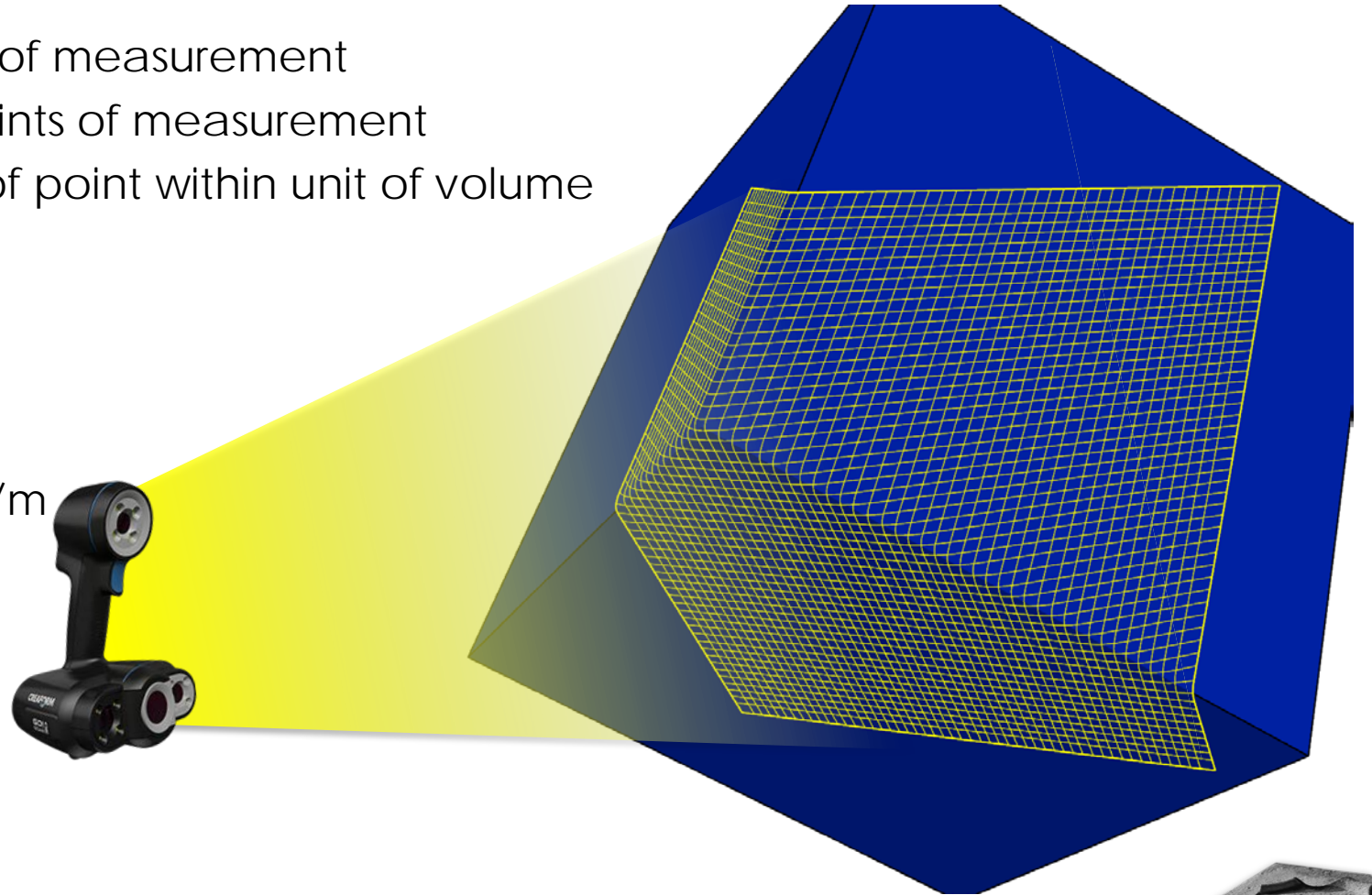
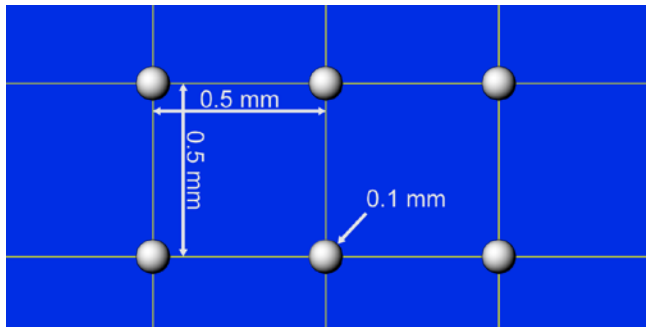

**RESEARCH  
TECHNOLOGIES**

INDIANA UNIVERSITY  
University Information Technology Services



**PERVASIVE TECHNOLOGY  
INSTITUTE**

INDIANA UNIVERSITY



# Hardware-Based 3D Scanning

## Understanding the Limitations

- *Example: Elephant at 0.5, 1.0, and 2.0 mm resolution*

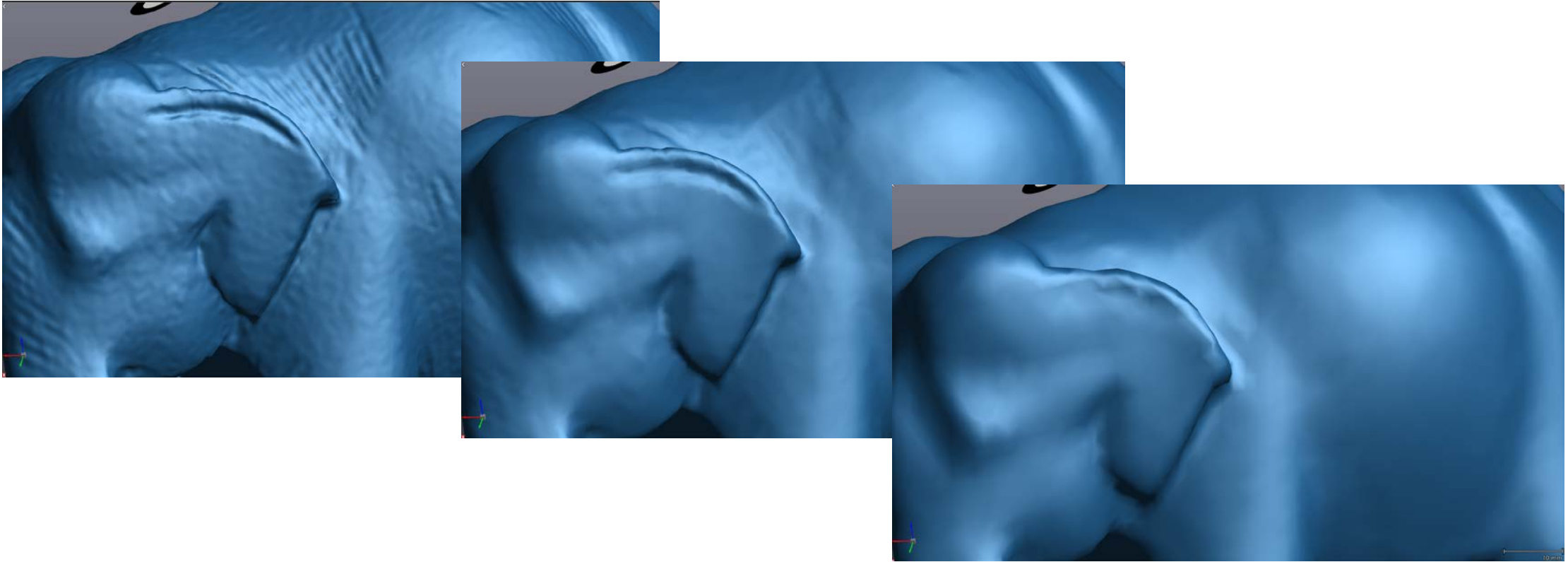

**RESEARCH  
TECHNOLOGIES**

INDIANA UNIVERSITY  
University Information Technology Services



**PERVASIVE TECHNOLOGY  
INSTITUTE**

INDIANA UNIVERSITY



# 3D Digitization

## Post-Processing

- Target applications
  - Digital preservation
  - Web delivery and interactive apps
  - 3D printing
  - Redesign



- Post-processing techniques
  - Polygon decimation
  - Polygonal hole filling
  - Color Preservation
  - Texture compression
  - Parameterization



**RESEARCH  
TECHNOLOGIES**

INDIANA UNIVERSITY  
University Information Technology Services



**PERVASIVE TECHNOLOGY  
INSTITUTE**

INDIANA UNIVERSITY

# 3D Digitization Post-Processing

- Target App: *Web Delivery*
- Post-processing techniques
  - *Polygon decimation*: Reduce the number of polygons for faster web delivery
  - *Color preservation*: Re-project source color when polygon manipulation destroys color
  - *Texture compression*: Save as JPG!

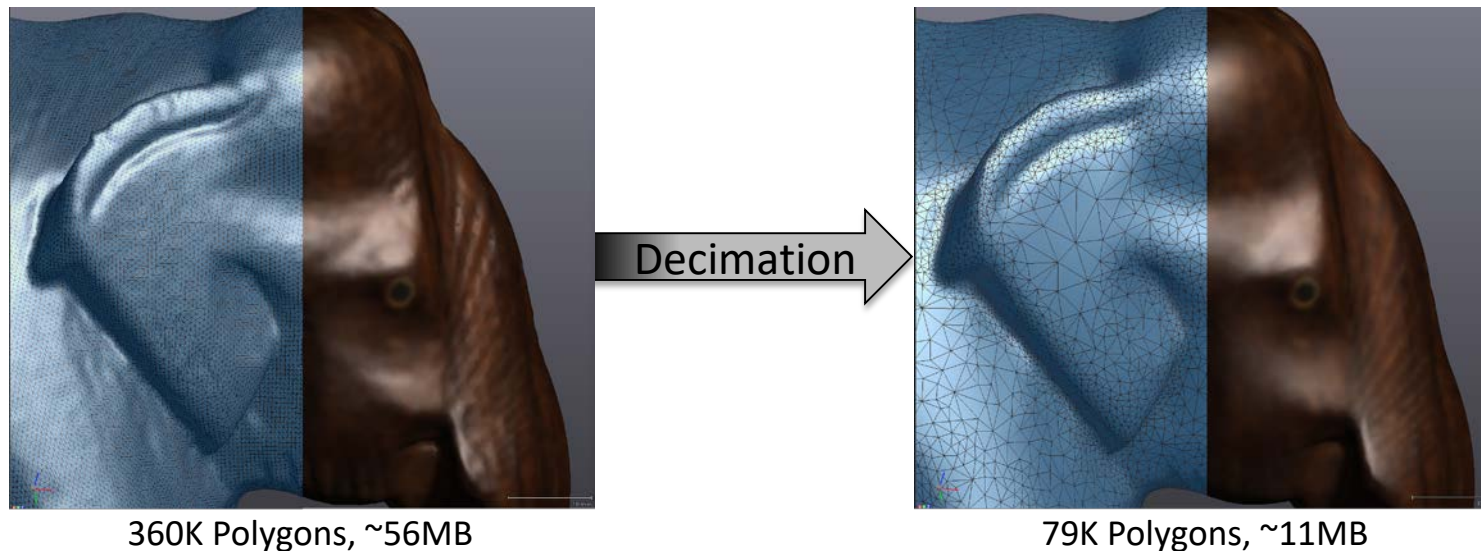

**RESEARCH  
TECHNOLOGIES**

INDIANA UNIVERSITY  
University Information Technology Services



**PERVASIVE TECHNOLOGY  
INSTITUTE**

INDIANA UNIVERSITY



# 3D Digitization Post-Processing

- Target App: *3D Printing*
- Post-processing techniques
  - *Polygonal hole filling*: Find and repair holes in the mesh including removal of cross-facing polygons resulting in watertight mesh

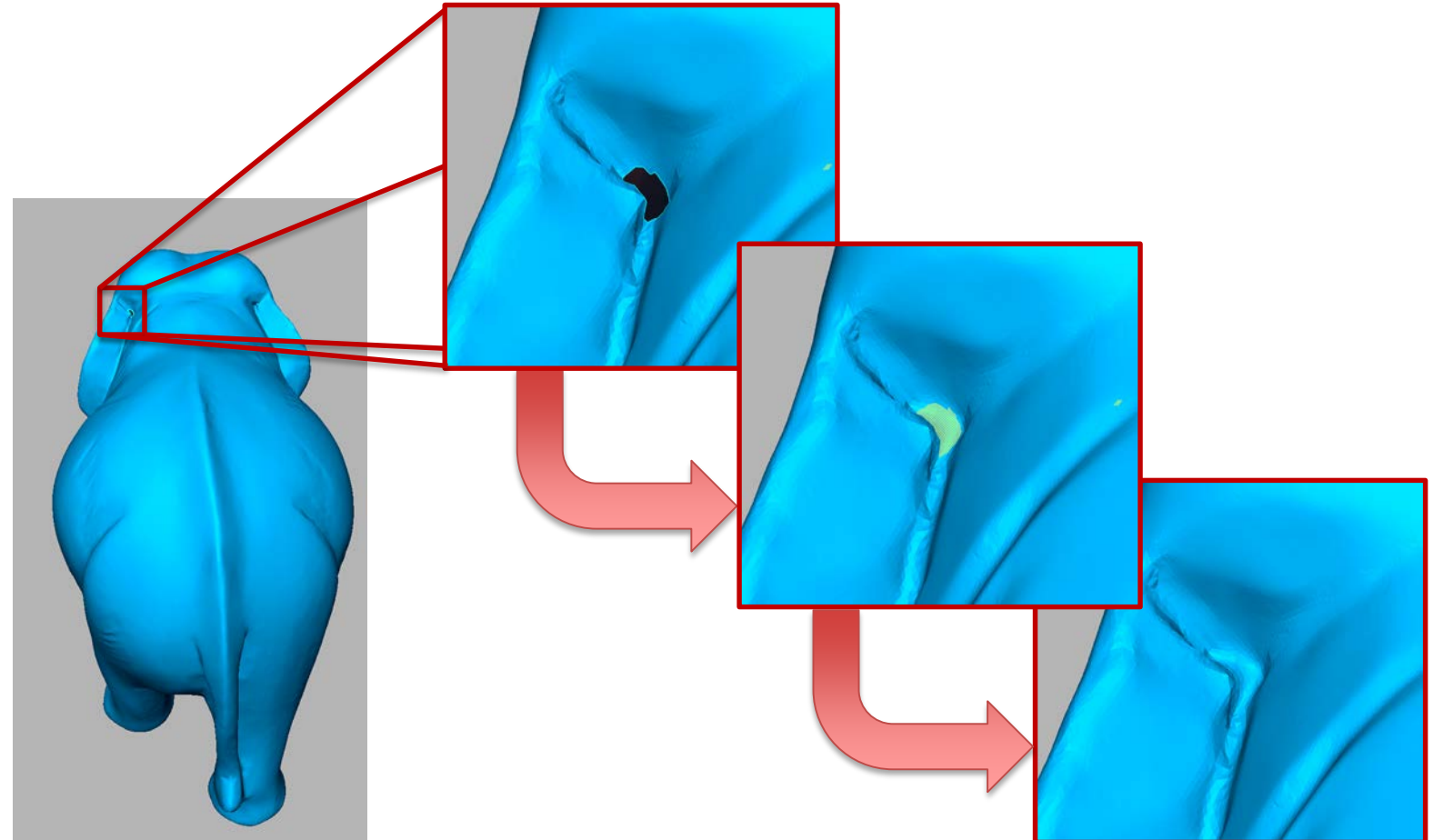

**RESEARCH  
TECHNOLOGIES**

INDIANA UNIVERSITY  
University Information Technology Services



**PERVASIVE TECHNOLOGY  
INSTITUTE**

INDIANA UNIVERSITY



# 3D Digitization

## Post-Processing

- Target App: *Redesign*
- Post-processing techniques
  - *Parameterization*: extracting the parameters that mathematically define geometric objects
    - Primitives: Spheres, Cylinders, Planes, Cubes, Cones, Pyramids, ...
    - Parametric equations for curves and surfaces
- Example: *Chunkey Stone Redesign*

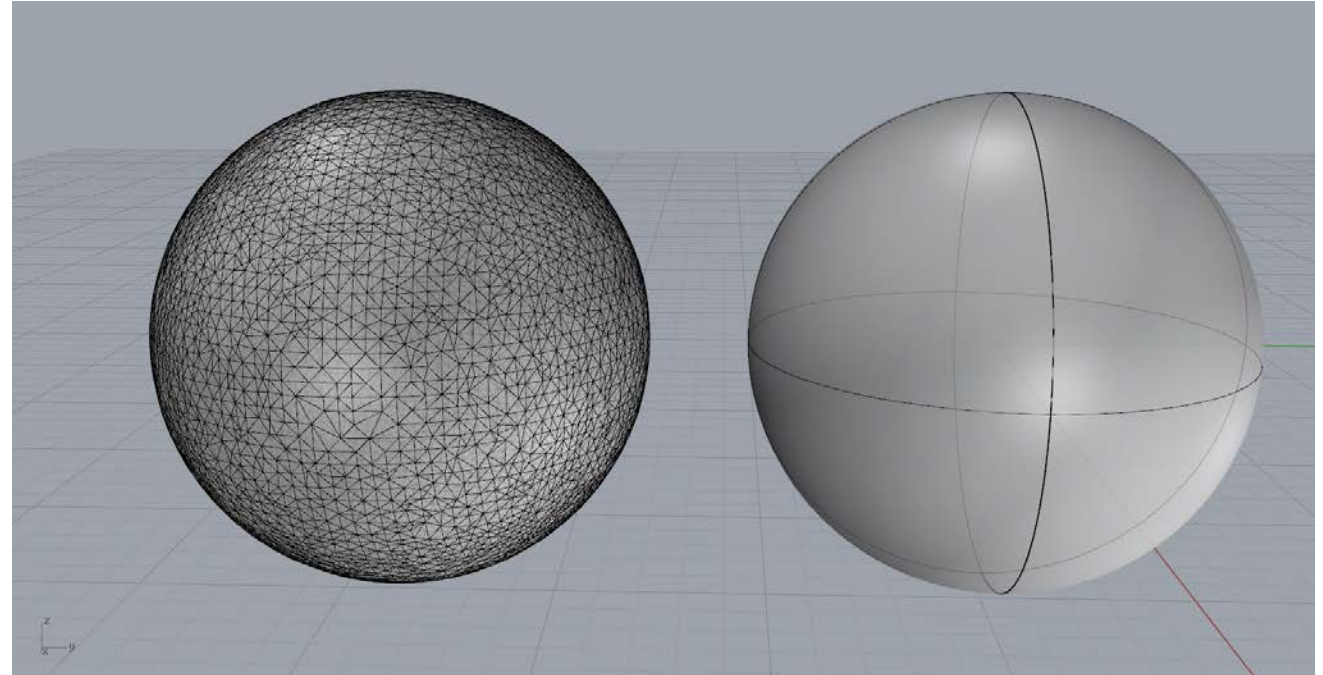

Points and Polygons

Sphere with Center  
and Radius



**RESEARCH  
TECHNOLOGIES**

INDIANA UNIVERSITY  
University Information Technology Services



**PERVASIVE TECHNOLOGY  
INSTITUTE**

INDIANA UNIVERSITY



# 3D Digitization Post-Processing

- Target Example: Chunkey Stone redesign and reproduce for cultural heritage experience

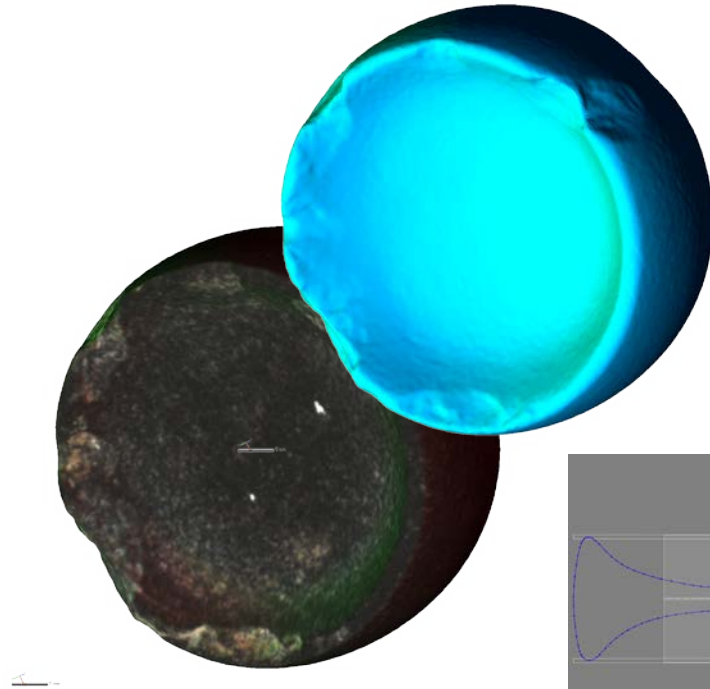

Scan Data

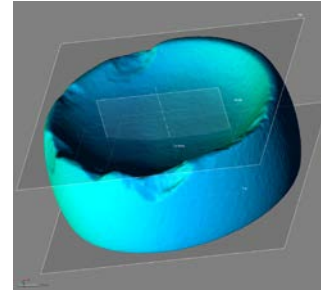

1. Extract Parameters

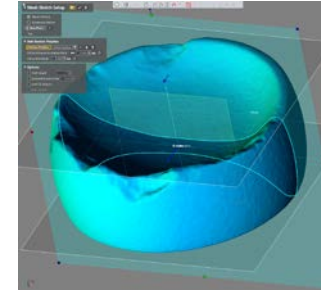

2. Cross Section

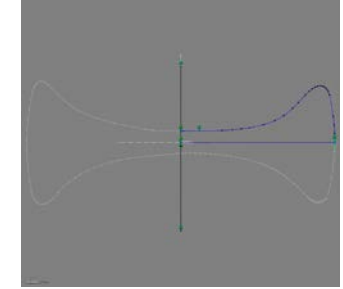

3. Sketch 1/4 Section  
Profile

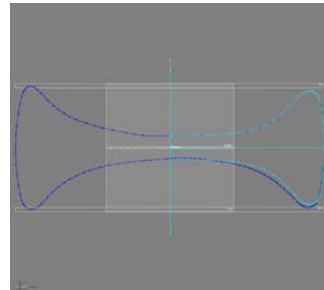

4. Mirror to 1/2 Profile

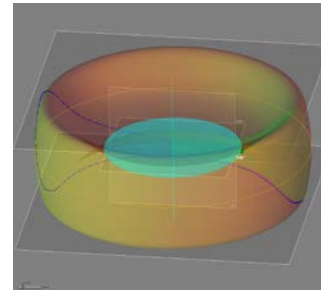

5. Revolve



6. Finished Part

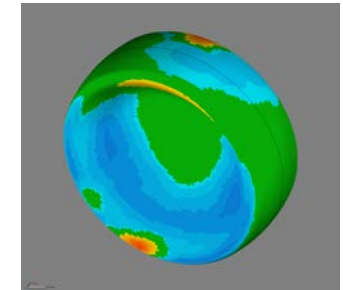

7. Deviation Map



**RESEARCH  
TECHNOLOGIES**

INDIANA UNIVERSITY  
University Information Technology Services



**PERVASIVE TECHNOLOGY  
INSTITUTE**

INDIANA UNIVERSITY





# 3D Digitization

## Available IU Services

- Hardware based 3D surface scanning (AVL)
  - Small collections
    - Assess, digitize and process for you
  - Large collections
    - Train you to assess, digitize, and process
    - Support for hardware and software
    - Schedule equipment
- Photogrammetry (CyberDH)
- Volumetric scanning (IU SoM Preclinical Imaging)
- Post-processing of digitized 3D data (AVL)
  - We process or train post-processing techniques
  - Recommend existing workflows for targeted applications
  - Develop new workflows as needed



**RESEARCH  
TECHNOLOGIES**

INDIANA UNIVERSITY  
University Information Technology Services



**PERVASIVE TECHNOLOGY  
INSTITUTE**

INDIANA UNIVERSITY







# 3D Digitization Workflows

- AVL Scanning Workflows
  - VXEelements
  - ZBrush
  - Geomagic Design X
  - Autodesk Meshmixer
  - 3D Slicer
  - More coming soon...



**RESEARCH  
TECHNOLOGIES**

INDIANA UNIVERSITY  
University Information Technology Services



**PERVASIVE TECHNOLOGY  
INSTITUTE**

INDIANA UNIVERSITY



# 3D Digitization

## Available IU Technologies

- 3D Surface scanning hardware
  - Creaform GoScan 20 for objects ~0.5" to 2'
  - Creaform GoScan 50 for objects ~6" to 10'
  - Makerbot scanners in 3D Print Labs
- Software (**Bold = Established Workflows**)
  - **Creaform VXElements** (available for IU systems)
  - **Geomagic Design X** (limited availability)
  - **Zbrush** (limited availability)
  - Autodesk Tools available to all @ IU
    - **MeshMixer**, Maya, Max, Inventor, Mudbox, ...
  - Free options like Meshlab, Blender, ...
  - **Slicer3D**
  - **Agisoft Photoscan on Karst** (Details: 04-06-2018)



Geomagic



RESEARCH  
TECHNOLOGIES

INDIANA UNIVERSITY  
University Information Technology Services



PERVASIVE TECHNOLOGY  
INSTITUTE

INDIANA UNIVERSITY

# 3D Printing

- IU UITS 3d Print Labs
  - MakerBots
  - Web: <https://pie.iu.edu/apps/3Dprint/>
  - IUB Wells Library West Tower, 4th Floor
  - IUPUI ICTC, 1st Floor
- IUB SOAAD Mad Labs
  - Web: <https://soaad.indiana.edu/creative-activity/facilities/mad-labs/index.html>
- IUPUI Herron Think It Make It Lab
  - Formlabs 1+, Objet30 Pro, Ultimaker
  - Web: <http://www.herron.iupui.edu/think-it-make-it-lab>
- IUPUI University Library 3D Printing Studio (Makerbots)
  - Web: <http://www.ulib.iupui.edu/tech/3d>
- Shapeways: [www.shapeways.com](http://www.shapeways.com)

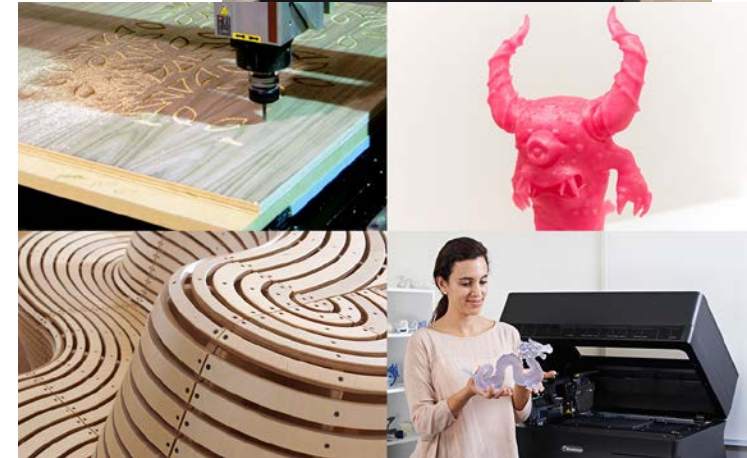

**RESEARCH  
TECHNOLOGIES**

INDIANA UNIVERSITY  
University Information Technology Services



**PERVASIVE TECHNOLOGY  
INSTITUTE**

INDIANA UNIVERSITY



# Thanks!

- UITS 3d Print Labs: Todd Kirk, Rob Lastinger, and Andy Webb
- IUPUI Herron Think It Make It Lab: Shelley Spicuzza
- Indiana Institute for Biomedical Imaging Sciences Preclinical Imaging: Brian McCarthy
- Ruth Lilly Medical Library: Jennifer Herron
- Center for Digital Scholarship: Jennifer Johnson and Anna Proctor
- Center for Biological Research Collections: Gary Motz
- Online Resources, Inc. : JD and Jay Schaumberg
- CyberDH: Tassie Gniady, Anna VanderJagt
- Mad Labs: Ryan Mandell
- IU East Fine Arts: Carrie Longley



**RESEARCH  
TECHNOLOGIES**

INDIANA UNIVERSITY  
University Information Technology Services



**PERVASIVE TECHNOLOGY  
INSTITUTE**

INDIANA UNIVERSITY



# Demos and Discussions

- Creaform GoScan 20 and 50 Demonstrations
  - Your Objects?
- Check out our 3D Prints



Magical Gavel



Magical?

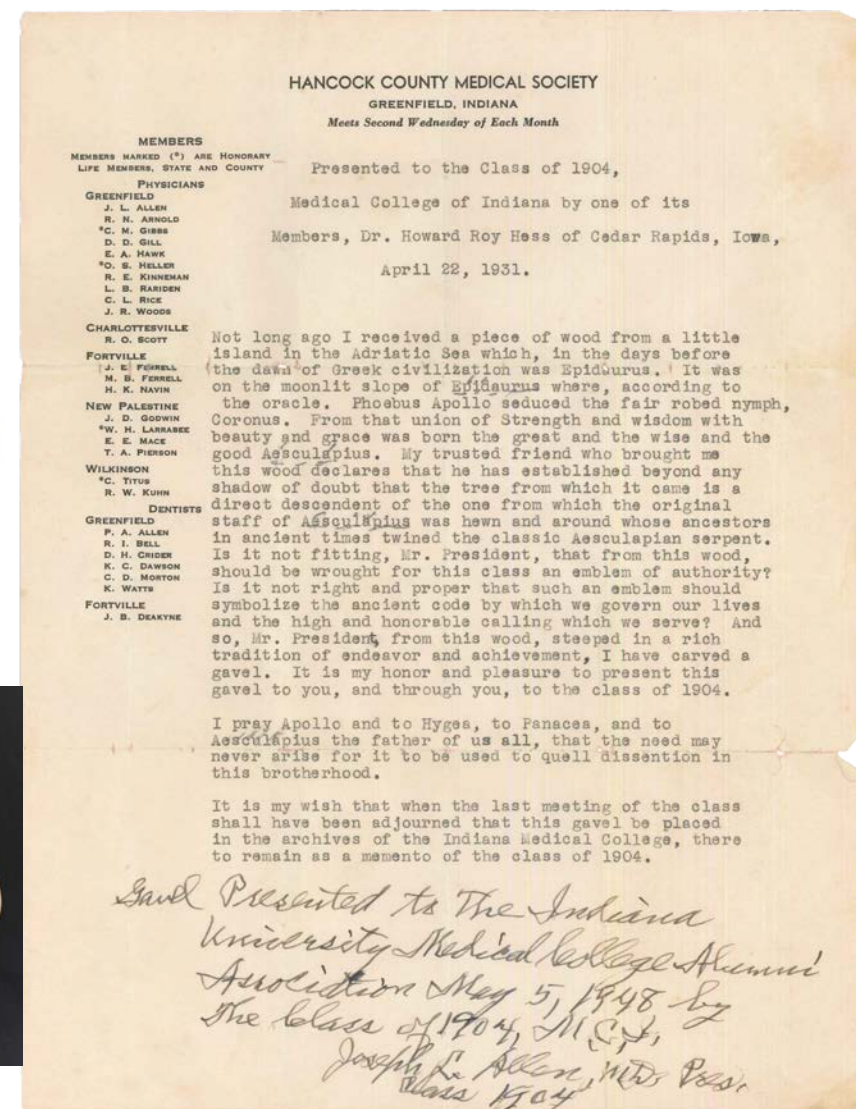

**RESEARCH  
TECHNOLOGIES**

INDIANA UNIVERSITY  
University Information Technology Services



**PERVASIVE TECHNOLOGY  
INSTITUTE**

INDIANA UNIVERSITY