

line, relocation of the dump shielding and several auxiliary components and supply line.

The ion optics for the beam transmission mode for the K600 at 0° is established. In this mode the beam is transmitted through the spectrometer end exits into a special port into a dump. Mounting fixtures are presently installed in order to mount the existing focal plane detector in the high dispersion mode. A crucial test will be conducted in August in order to test if the detectors can be operated so close to the transmission dump and if beam halo and background sources can be eliminated.

THE K600 FOCAL PLANE POLARIMETER

S.W. Wissink, A. Eads, A.K. Opper, T. Rinckel, R. Sawafta,
P. Schwandt, K.A. Solberg, and E.J. Stephenson
Indiana University Cyclotron Facility, Bloomington, Indiana 47408

During 1988, we completed the construction and calibration of a high-efficiency polarimeter for detection of intermediate-energy charged particles, currently mounted downstream from the medium-dispersion focal plane of the K600 spectrometer system. All components of the dedicated electronics are installed and tested, acquisition and preliminary analysis software exists, and two extended running periods of approximately ten days each (for initial calibration of the polarimeter¹ and for experiment E306²) have resulted in detailed measurements of the polarimeter's efficiency, momentum bite, effective analyzing power, and count rate capabilities which have met or exceeded all design goals.

As shown schematically in Fig. 1, the focal plane polarimeter (FPP) consists of a thick carbon block, followed by two sets of paired x - y multiwire proportional chambers, and two planes of plastic scintillator. The high-density (1.78 g/cm^3) graphite target serves as the polarization analyzer; thicknesses of 1.27 cm, 3.81 cm, or 5.08 cm are currently available. For incident proton energies between 120 and 200 MeV, the p - ^{12}C analyzing powers are large in magnitude, and have been carefully studied for both elastic and inelastic scattering processes.³ The graphite block is carefully counterbalanced, and can be moved vertically in or out of the reaction plane in a matter of seconds. The entire analyzer mounting system can also be completely removed with relative ease if need be for calibration or alignment studies.

After extensive bench testing, the two sets of x - y chambers were installed in their final location in July 1988. A complete set of spare chambers has also been built and tested. The smaller x and y chambers have active areas that measure approximately 70 cm horizontally and 30 cm vertically, while the corresponding numbers for the larger chambers are 100 cm and 50 cm, respectively. Readout of the wire chamber information occurs via the LeCroy PCOS III system, which offers several advantages over either direct coincidence register readout or highly multiplexed configurations. A feature crucial for our application is the rapid ($< 500 \text{ ns}$) encoding of the first wire hit in real-time, with presentation of the encoded output at an ECLport. This information is used as input to a second-level trigger processor for on-line rejection of events in which the detected

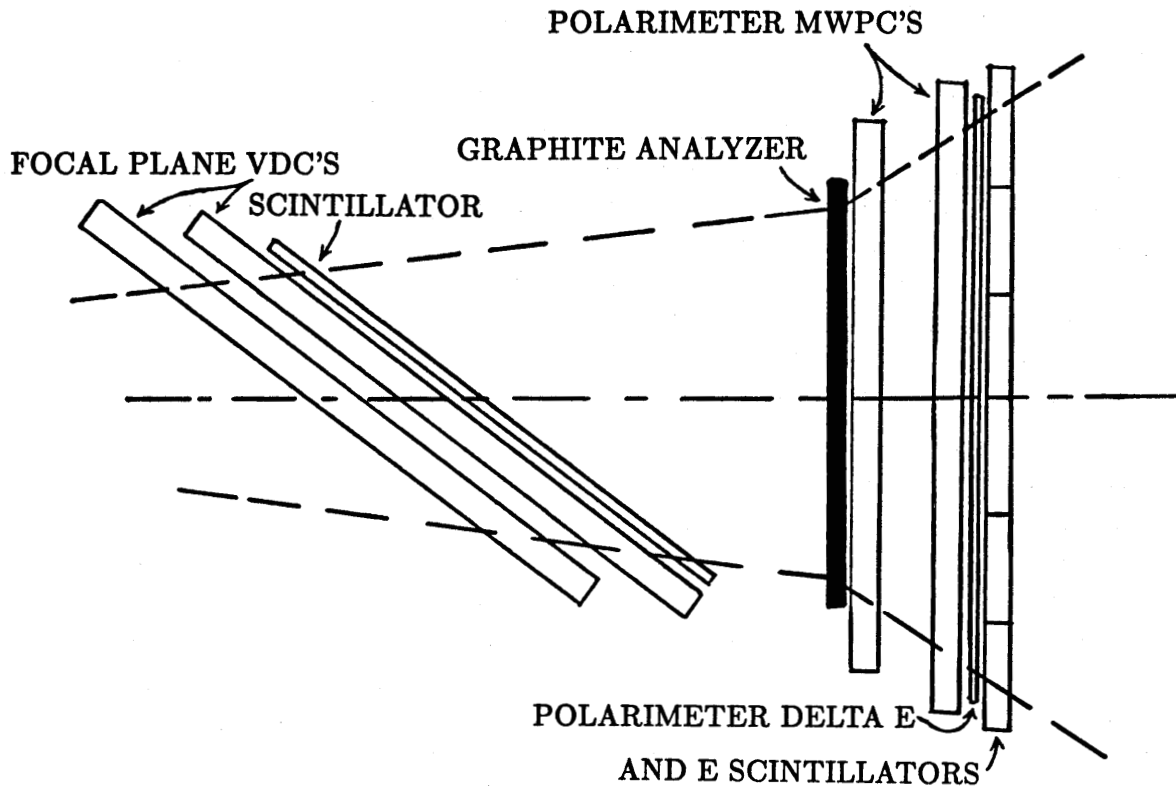

Figure 1. Schematic representation of the K600 spectrometer focal plane and polarimeter systems, as viewed from above. The functions of the various elements are described in the text. The scattered beam enters from the left of the drawing, and typical trajectories are indicated by the dashed lines.

particle underwent no significant scattering in the analyzer (carbon) target (see below for details). We estimate that, under optimum conditions, this could increase our data acquisition rate capability by approximately a factor of twenty; factors of ten to fifteen have already been demonstrated, though our inclusion of prescaled "straight-through" events reduces this somewhat. Other PCOS III features include remotely programmable thresholds for each chamber card, computer control of delay lengths ("software cable-cutting") for each latching module, clusterization of adjacent wire hits within the encoder for each chamber, and minimal word transfer over the (slow) CAMAC dataway. Under typical running conditions, full information from all four MWPC's can be compacted into less than ten 16-bit words for readout by the MBD.

The scintillator planes consist of 0.64 cm and 7.62 cm thick NE102 stock. Depending on the incident particle type and energy, these can serve as either a ΔE — E pair or as a ΔE —high-resolution- ΔE combination. The 0.64 cm scintillator is a single sheet, viewed by four low-gain 5 cm photomultiplier tubes (Hamamatsu R329), while the 7.62 cm thick plastic has been segmented into six vertical non-overlapping sections, each viewed by two similar 5 cm tubes. This segmentation was considered necessary in light of the high background rates that may arise under certain spectrometer running conditions and the

large volumes of scintillator involved. All of the thick plastic segments were equipped with rectangular light guides at each end, using a geometry chosen (via Monte Carlo response simulations) to make light collection over the scintillator area as uniform as possible. After fan-out, the sixteen anode signals are discriminated and fed into another second-level trigger processor, which allows user-selectable logic levels to be generated for all possible combinations of the 16 inputs. Thus, for the scintillator system, the high-voltage bias applied to the photomultiplier tubes, the discriminator thresholds, and even the 16-fold scintillator coincidence logic are all under remote computer control. After software correction for varying angles of incidence, resolutions of 3-4% have been obtained in the thick scintillator, with a uniformity over the entire active surface of better than 2% in response to monoenergetic particles.

Electronically, a first-level trigger is generated by a coincidence between the S_1 mean-timer (used for timing in the focal plane VDC's) and a four-fold AND of the ΔE signals. If this trigger is not vetoed by the wire chamber high voltage alarm or a "busy" signal from the event trigger module, then all focal plane and polarimeter ADC's and TDC's are gated/started, and the four PCOS encoders are enabled. The focal plane multiplexers are then checked to be sure that there was at least one struck wire in both the front and rear VDC's. If so, we have a "good focal plane" event, a prescaled fraction of which (typically 5%) are always sent to the event trigger module. At the same time, the first-hit information from each of the four polarimeter wire chambers is sent from the encoder ECLports to a pair of LeCroy Memory Look-up Units (MLU's). If the correlation between the two x chambers *and* the correlation between the two y chambers indicate that the proton went essentially straight through the carbon analyzer, then there is no useful information to be gained from this event concerning the proton polarization, and the event can be discarded. (These correlations are determined empirically by collecting data with the carbon analyzer removed, drawing a window around the locus of unscattered events, then down-loading this information into the LRS 2372 MLU, which performs the same bit test in hardware as does our window in software.) Good focal plane events which are not vetoed by the MLU conditions are then OR'ed with the prescaled focal plane event stream to provide our final event definition. Trigger signals from events which do not meet these criteria are then used to clear and reset all CAMAC and NIM modules to await the next event. The total time required to make these decisions and reset all modules is just under 5 μ s.

After a few short periods of split beam for initial hardware tests, we received our first dedicated beam during November 1988 for a polarimeter calibration run that is described in detail elsewhere in this report.¹ We also developed a "first-pass" set of software conditions that could be easily appended to the existing focal plane analysis package; these conditions are also discussed in the context of the calibration measurement.¹ During this run (approximately 16 shifts of beam) we were able to thoroughly test all aspects of the FP/FPP electronics (concentrating especially on the fast reject and clear electronics mentioned above), debug and substantially improve our increasingly complex acquisition and sorting software, and add some much-needed on-line diagnostic checks to our analysis programs. We accomplished essentially all of the above goals in our allocated beam-time, with no time lost to FPP hardware problems or electronics optimization, having performed most of these tasks with a few shifts of split beam from the Cooler prior to receiving ded-

icated beam. At each of the three incident proton energies required, only 2 hours or so were required to achieve ~ 40 keV resolution, more than adequate for our purposes.

It is useful to point out the difficulties involved in trying to calculate the effective parameters of the polarimeter from measured values for cross sections and analyzing powers. Each of these quantities must be averaged, with appropriate weighting, over incident energy (since the protons interact at different depths within the carbon analyzer), over excitation energy (due to the relatively poor energy resolution achievable in the polarimeter scintillators), and over scattering angle (due to multiple scattering, largely in the carbon block). All of these factors, and the relative weightings, are also affected as much by software choices as by hardware. It is imperative, therefore, that one arrive at a reasonable, reproducible procedure by which one sets these hardware and software cuts, and that this procedure can be easily transferred from calibration running to production running. Our preliminary analysis of the calibration data shows no systematic dependence of either the polarimeter efficiency or effective analyzing power on the position of the scattered proton's trajectory along the focal plane, and all false asymmetry terms were determined to be zero within error.¹

In January 1989 we received a second block of dedicated beam-time for E306, a measurement of the spin observables $D_{NN'}$ and P for selected unnatural-parity transitions in ^{12}C and ^{16}O . This work is also described earlier in this report.² Prior to this run, we had made several changes and improvements to the focal plane polarimeter system, each of which had to be thoroughly tested. We incorporated more sophisticated algorithms for determining proton trajectories and energy losses in the polarimeter wire chambers and scintillators. "Intelligent" diagnostic software used both cumulative and incremental scaler values to calculate spin-dependent wire chamber efficiencies, system dead-times, sampling fractions, and hardware-rejection factors which were crucial in rapidly noting and identifying possible hardware or analysis problems. Electrically isolating the scintillator high voltage power supply greatly reduced noise in the scintillator signals, while switching from twisted-pair to co-axial cables for our ADC delay lines eliminated cross-talk problems noted in replay of the calibration data. As a final check on the whole system, we began our production run by repeating a calibration point, which compared favorably with our earlier work.

To increase our acquisition rate for selected data, we employed several schemes to eliminate events outside the excitation energy region of primary interest. We intercepted the elastically scattering protons with a copper block mounted on a movable track inside the K600 vacuum box, thus preventing these events from producing even first-level triggers, while disabling particular pre-amp cards on the VDC's of the K600 focal plane effectively vetoed regions of either very low or very high excitation at a second-level in hardware. For future runs, we are investigating the use of veto paddles mounted directly behind the focal plane S_1 scintillator, or the possibility of replacing the existing S_1 scintillator (approximately 1 m in length) with a much shorter version, though the effects of this latter technique on the VDC drift time spectra would need to be studied in some detail.

Though not directly related to the operation of the focal plane polarimeter, we are also commissioning much of the additional equipment that will be required for full polarization transfer capabilities at IUCF. This includes the successful installation and beam-optics

tests of two superconducting spin-precession solenoids in the high-energy beamlines, development and calibration of associated in-beam transmission polarimeters, the addition of two horizontal ("y") drift chambers to the K600 focal plane system for complete vertical trajectory information, and structural rearrangement of the southern shielding wall in the K600 experimental area to allow for rotation of the spectrometer system to angles as large as 44° to the right of the beam. Each of these projects is described in detail elsewhere in this document, and is proceeding essentially on schedule. We are fairly confident that all of these tasks will be completed shortly, and that the first in-plane spin transfer measurements on the K600 will be carried out before the end of 1989.

1. E.J. Stephenson *et al.*, "Calibration of the K600 Focal Plane Polarimeter", IUCF Scientific and Technical Report, 1988.
2. A.K. Opper *et al.*, "Measurements of the Spin Observables $D_{NN'}$ and P in Inelastic Proton Scattering from ^{12}C and ^{16}O at 200 MeV", IUCF Scientific and Technical Report, 1988.
3. see, for example, IUCF Scientific and Technical Report, 1982, p. 182-188.

TARGET LAB TECHNICAL STATUS

W. Lozowski and J. Hudson

Target preparations for 1988 included: $^{6,7}\text{Li}$, $^{10,11}\text{B}$, $\text{H}_3^{10}\text{BO}_3$, $^{10}\text{B}_2\text{O}_3$, CD_2 , CD_2/CH_2 mix, $^{12,13}\text{C}$, CF_2 , $\text{Si}^{17,18}\text{O}_2$, Si , ^{34}S , ^{39}KF , Co , $^{87,88}\text{Sr}$, Ag , ^{118}Sn , Ag , and ^{208}Pb .

Target development work for 1988 included:

1) An evaporated $^{10}\text{B}_2\text{O}_3$ target of 3.5 mg/cm^2 was prepared for an experiment with the K600. The oxide was obtained by thermal decomposition of isotopically enriched boric acid. To remove all hydrogen (a serious contaminant at some angles for the experiment), the decomposition had to be carefully controlled in high vacuum over a period of ten hours. A small tube furnace, for use within the high-vacuum evaporator, was constructed in the lab for this purpose. The oxide was then evaporated onto $260 \mu\text{g/cm}^2$ Au leaf. The details of this procedure are contained in a contribution to the December 1988 issue of the International Nuclear Target Development Society (INTDS) Newsletter.

2) Much effort was devoted to achieving $2\text{-}3.5 \text{ mg/cm}^2$ ^{208}Pb targets with 28 keV resolution and ≤ 0.001 Atom % O_2 and C . The difficulty was due to the chemical reactivity of pure Pb, the need to conserve the expensive isotope, and the need to exclude all heavy elements from the target. Although great targets were not achieved until the first week of February, 1989, the progress in 1988 was: a) ^{208}Pb metal, more pure than that supplied by ORNL, was obtained from $^{208}\text{Pb} \text{ CO}_3$ with an efficiency of 98.36%. The method developed